

Product Highlights

- Maximizes bus efficiency via Look-Ahead command processing, Bank Management, Auto-Precharge and Additive Latency support
- Minimal latency achieved via parameterized pipelining
- Achieves high clock rates with minimal routing constraints
- Supports full rate and half-rate clock operation
- Full run-time configurable timing parameters and memory settings
- Supports 2T timing
- Full set of Add-On Cores and ASIC DDR PHY available
- Minimal ASIC gate count
- Broad range of ASIC and FPGA platforms supported
- Source code available
- Customization and Integration services available

Block Diagram

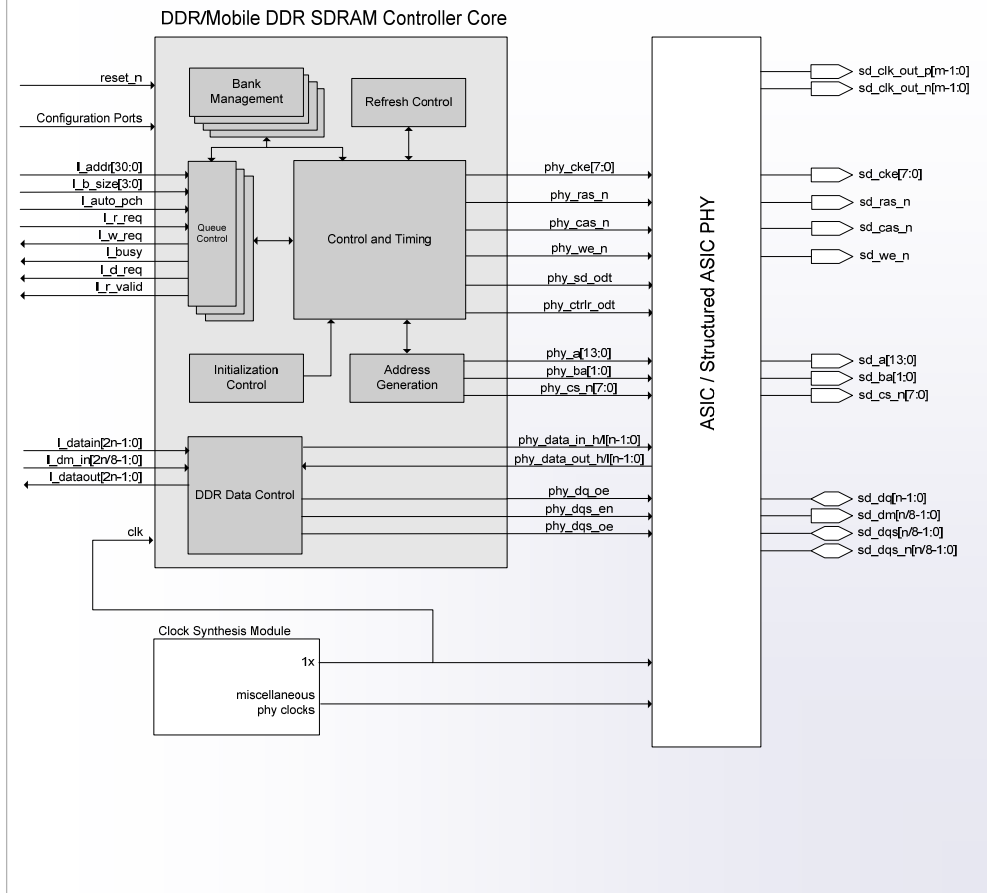

Product Overview

Northwest Logic's Double Data Rate (DDR) SDRAM Controller Core is designed for use in applications requiring high memory throughput, high clock rates and full programmability.

The core accepts commands using a simple local interface and translates them to the command sequences required by DDR SDRAM devices. The core also performs all initialization, refresh and power-down functions.

The core uses bank management modules to monitor the status of each SDRAM bank. Banks are only opened or closed when necessary, minimizing access delays. Up to sixteen banks can be managed at one time.

The core queues up multiple commands in the command queue. This enables optimal bandwidth utilization for both short transfers to highly random address locations as well as longer transfers to contiguous address space. The command queue is also used to opportunistically perform look-ahead activates, precharges and auto-precharges further improving overall throughput.

The core is provided with run-time programmable inputs for all

memory timing parameters and configuration settings. This ensures compatibility with all DDR SDRAM configurations. The core also supports 2T timing.

Northwest Logic offers a full set of Add-Cores and an ASIC DDR PHY for use with the core.

Northwest Logic also provides a complete set of quick-turn design services including IP Customization and Logic, Board, Software Development services. Contact Northwest Logic for a quote.

Product Deliverables:

- Core (Netlist or Source Code)
- Comprehensive Verification Suite (Source Code)
- Complete Documentation
- Expert Technical Support & Maintenance Updates